

# BUILDINGS AND FURNITURE CONSTRUCTED WITH ROUND MORTISE AND TENON JOINTS FROM SALVAGE MATERIALS AND SMALL DIAMETER TIMBER

Carl A. Eckelman and Eva Haviarova

## ABSTRACT

Although round mortise and tenon construction have been used in furniture construction for hundreds of years, their value in the solution of human need problems has never been fully appreciated. Round mortise and tenon joint construction allows low cost, durable furniture and buildings to be constructed from essentially waste wood materials using only the simplest manufacturing techniques.

The use of round mortise and tenon joinery in conventional building frame construction provides a means of utilizing extensive wood plantation thinnings in the solution of housing shortages as well as a means of producing low cost farm and light industrial buildings. It is anticipated that standardized modular designs can be created that require a minimum number of part sizes and limited quality control practices in order to produce easy to build, robust, durable frame construction.

This type of construction can be built in even the most remote regions of the world from locally available materials using only low technology process. Only a small investment is required to empower local communities to develop their own production facilities.

Wood material for construction of buildings and furniture could be obtained from much of the material that is currently considered sawmill waste from semi-processed material such as pallet deck boards, from small woody stems obtained from plantation thinnings, or from saplings grown specifically to provide the materials of construction.

Use of these materials in house frame construction, farm building construction, and light industrial building construction provides an enormous outlet for plantation thinnings and at the same time provides solutions to acute social problems in areas where affordable housing is needed.

Round mortise and tenon joints and their simple construction provide a rare opportunity for using what would otherwise be considered wood waste while improving the quality of life of many people.

## INTRODUCTION

Round mortise and tenon joints have been used in furniture construction for many years, but the true potential of these joints has seldom been recognized or utilized. Noteworthy exceptions to this statement are the "Shaker" ladder back chair and similar "mountain" chairs—the latter usually constructed of unseasoned woods—similar to that shown in Figure 1. In these chairs, round tenons, cut on the ends of the side stretchers, fit into matching round

mortises bored into the front and back posts. These chairs derive their outstanding durability both from their design and their construction. Usually such chairs are constructed with three side stretchers. Owing to the relatively small size of the stretchers relative to that of the front and back posts, internal bending forces developed in the chair side frame during use are essentially evenly distributed to each of the six joints. Thus, the internal bending force acting on any joint is minimized so that no joint is overstressed. In addition, the joints are subjected almost exclusively to bending rather than tensile forces. Round mortise and tenon joints are able to develop their full bending strength even though loosely constructed, whereas the same joints will immediately pull apart if subjected to tensile forces. The net result is that by eliminating tensile forces through design, the need for close quality control in construction of the joints has also been eliminated.

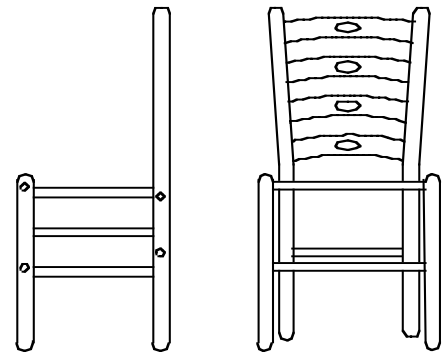

Figure 1. —"Early" U.S. chairs constructed with round mortise and tenon joints.

The outstanding characteristics of round mortise and tenon construction has recently been demonstrated in a project devoted to the construction of durable school furniture constructed from wood waste including wood derived from plantation thinnings.

In this project, chairs and desks (Figs. 2 and 3) suitable for use in elementary school grades were constructed and subjected to performance tests used to evaluate furniture intended for adult use in university libraries. The experimental furniture performed as well as heavy-duty library furniture.

Importantly, it was found that the tenons developed the full bending strength of the material of which they were constructed. Furthermore, the joints did not loosen nor show signs of fatigue during testing. To the contrary, during cyclic testing, the joints developed about 25% more strength than would be predicted on the basis of the static bending strength of the wood—which is in keeping with strengths predicted for short duration loading of wood. Presumably, building frames constructed with round mor-

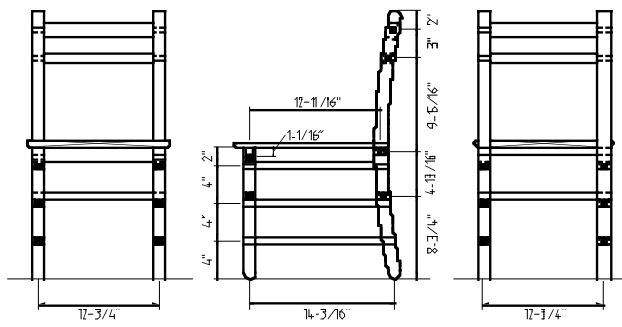

Figure 2.—Solid wood chair constructed with round mortise and tenon joints.

tise and tenon joints also would profit from this behavior in regions prone to earthquakes.

### CUTTING ROUND TENONS

Traditionally, round tenons have been cut on a lathe, or, in the case of rustic furniture, with a draw knife. Various types of rotating cutter heads are also available today that are often used by home craftsmen. A particularly important finding for this project, however, was that deep hole saws may be used to cut high quality round tenons that are both uniformly round and uniform in diameter from one piece to the next. A simple horizontal drilling device (Figs. 4 and 5) that simplifies and improves the quality of the cutting was developed in the laboratory. The principal components of the device are a one-fourth-horsepower electric motor, a wooden framework, and an inexpensive arbor, chuck, and hole saw. Total cost of the equipment should not exceed \$50 U.S. Presumably, this simple piece of equipment could be constructed and used in many remote regions of the world—provided electricity is available. Where electricity is not available, the electric motor can be replaced with two bearings and a shaft so that it can be powered by other means such as a gasoline engine. The one drawback to the use of deep hole saws is that residual material not removed by the hole saw from the end of a stretcher subsequently must be removed in another operation, although this is not difficult.

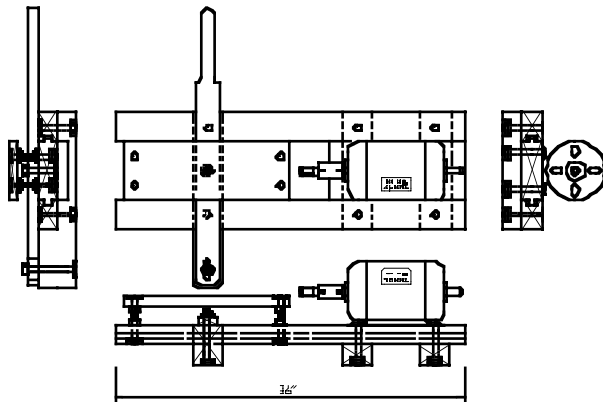

Figure 4.—Simple equipment used to cut round tenons on the ends of members.

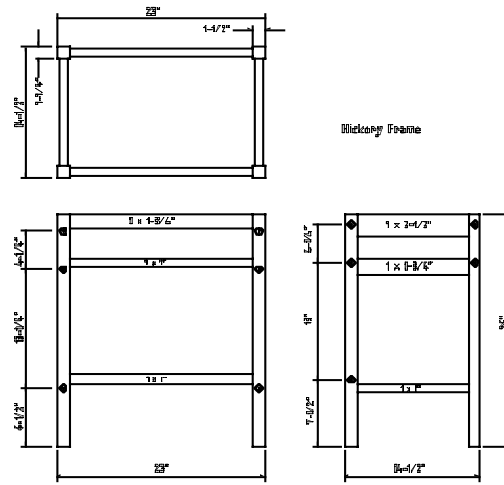

Figure 3.—Solid wood desk frame constructed with round mortise and tenon joints.

Comparable simple equipment for cutting tenons on the ends of large members to be used in conventional building construction is shown in Figure 8. In practice, the round or squared tree stem, or other structural member, is first positioned and secured in place in the machine. The hole saw is then advanced into the end of the member until the desired depth of cut (tenon length) is obtained. The excess material is then removed from around the tenon with a handsaw in order to leave a uniform rectangular shoulder on the member.

### SHRINK AND SWELL JOINT CONSTRUCTION

Shrink and swell joint construction refers to the process in which, tenons and mortises are machined while the materials of construction are maintained at an elevated moisture content or in the green condition. The tenon is cut slightly larger in diameter than the mortise. The part containing the mortise is then held at its current moisture content while the part containing the tenon is dried to a lower moisture content such as 5%. As the tenon dries, it

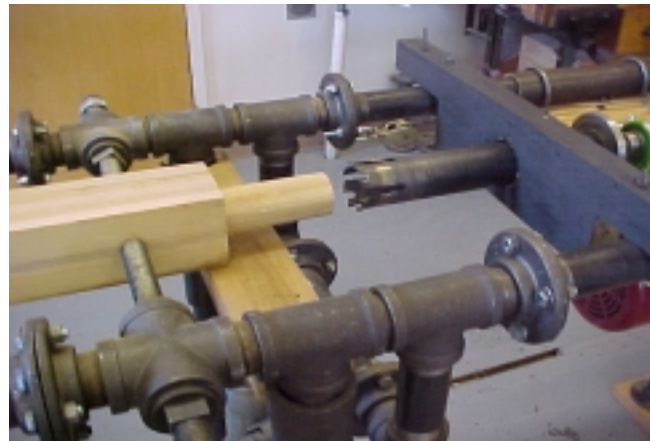

Figure 5.—Horizontal drilling press used to machine tenons.

shrinks to a size where its diameter is less than that of the mortise. The tenon is then inserted in the mortise and the two parts allowed to come to an equilibrium moisture content. During this process, the tenon swells while the mortise shrinks, and a “grip” fit is obtained.

This process works well in those regions of the world where the wood naturally comes to a high equilibrium moisture content such as 16%. In drier regions of the world with lower equilibrium moisture contents such as 6 to 8% a shrink fit can be obtained since the dried tenons will swell little, but nonetheless, relatively high tensile joint strengths can still be realized. The designer’s problem is reduced to specifying these fits in such a way that they can be produced in practice. This entails only the specification of the maximum and minimum diameters of the tenon and the mortise at the time they are cut.

### USE OF HOLE SAWS IN CUTTING TENONS

The hole saw is an invaluable tool for cutting tenons on the parts to be used in furniture or building frame construction in that these saws inherently cut tenons of uniform diameter without the need for close quality control by machine operators. Thus, once the appropriate mortise diameter has been determined, the construction of strong durable joints is reduced to the process of cutting the tenon with a hole saw and the mortise with a standard drill or cutter, drying the tenon until it fits into the mortise, and finally, inserting the tenon into the mortise and allowing it to swell while the mortise shrinks. Thus, with this construction, the need for close quality control is eliminated while an enduring construction is assured.

### GREEN BENDING OF WOOD

Many woods can be “free” bent sufficiently while green to form parts suitable for chair seats and back slats. In this process, the slats are simply bent to shape on a suitable jig and allowed to dry. In general, only simple equipment is required for the production of parts by this process.

Back posts may also be bent to shape in the green condition. In this process, the back post, while green, is supported at each end and subjected to a load perpendicular to its longitudinal axis at mid span as shown in Figure 6. In practice, a back post is bent as much as possible without fracturing and allowed to creep under load. The clamping nut (Fig. 6) is periodically tightened and the back post allowed to creep an additional amount. This process is repeated until the desired degree of curvature in the back post is obtained.

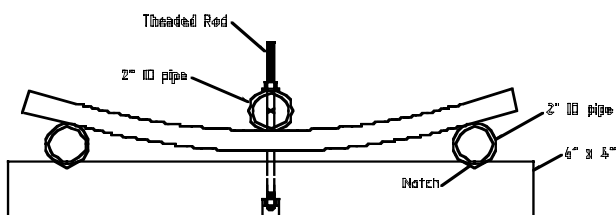

Figure 6.—Green bending of back posts. Note that posts are bent in pairs.

## MATERIALS OF CONSTRUCTION

Woody materials for construction of school furniture can be obtained from much of the material that is currently considered sawmill waste, from semi-processed material such as pallet deck boards, and from small woody stems obtained from plantation thinnings or from saplings grown specifically to provide the materials of construction. Many of the smaller furniture parts, in particular, can be cut from short and narrow boards salvaged from sawmill waste. Semi-processed materials are well-suited for the production of chair seat and back slats and for use in hybrid laminated construction. Small saplings can be incorporated directly into furniture construction, provide they have sound centers, but in many cases, such stems will need to be converted into squares or rounds or into processed parts before they can be used. In particular, small stems or saplings would be expected to be used for table and desk legs and front and back posts of chairs.

Green wood waste and stems are of particular value in that they can be bent to shape without the need for steam bending. Blanks for front and back posts for chairs, for example, can be bent to shape from squares or from small stems and subsequently bandsawn to final desired shapes. Similarly, seat and back slats may be bent from green material without the need for steaming.

Material for light frame building construction should come almost solely from small-stem woody plantation thinnings. Not all plantation thinnings are ideal for this type of construction—those with solid centers and superior juvenile wood properties are preferred. Use of this material in house frame construction, farm building construction, and light industrial building construction provides an enormous outlet for plantation thinnings and at the same time a solution to acute social problems, particularly in the area of affordable housing and other building constructions.

### SOLID WOOD FURNITURE CONSTRUCTION

The configuration of a typical solid wood chair frame is shown in Figure 2. In these chairs, the stretchers and back rails are first ripped to 7/8-inch width and cut to length. Round tenons are then machined on the ends of each part with a 3/4-inch outside diameter hole saw. Excess material is removed from around the tenons as needed.

Front rails are constructed of 7/8-inch thick by 1-3/4-inch wide material. Round tenons are cut off-center on the ends of this member in order to allow the matching mortises in the front posts to be drilled slightly further down from the top of the posts. The top chair-back rail is also constructed of 7/8-inch thick by 1-3/4-inch wide material, but the tenons are centered on the ends of this member. Holes (mortises) to receive tenons for stretchers or rails are drilled completely through the posts. The drill used to bore the mortises in the construction of the furniture is chosen to provide a “shrink and swell” fit between hole and tenon. The back posts in the chairs with sloping back legs are either “creep bent” or bandsawn to shape

Assembly techniques vary, but, in general, the side frames are constructed first. Walls of the holes and tenons

are first coated with adhesive. The tenons on the ends of the stretchers are then inserted in the holes and the assembly pulled together by means of bar clamps until the desired front-to-back side-frame dimensions are obtained. The side frame assemblies are then allowed to dry, and the holes for the front and back stretchers, etc., are then bored in the sides of the front and back posts. The walls of the holes are coated with adhesive, the ends of the tenons inserted, and the assembly pulled together as described above for the side frame assemblies.

The configuration of a sample solid wood desk frame is shown in Figure 3. Tenons are cut off-center on the ends of the top rails (Fig. 3) in order to avoid interference with the tenons on the ends of the front and side rails. In some cases, this practice also allows the mortises for the tenons to be located a reasonable distance below the top of a post.

## BUILDING FRAME CONSTRUCTION

Rectangular mortise and tenon construction was widely used in barns and other buildings in this and other countries, and there is a long history of its performance (Sloane 1967). Round mortise and tenon construction differs essentially only in the geometry of the joint, but information is lacking concerning its use in building frame construction—although the use of dowels as connectors is referenced (Stern 2001). Information is needed, therefore, concerning the basic characteristics and the idiosyncrasies of round mortise and tenon frame construction. Initially, background information is needed concerning the difficulties encountered in cutting round tenons and mortises of a size suitable for use with small-diameter roundwood, the ease of assembly with round mortise and tenon frame construction, and the integrity of the assembled frame.

Construction of a sample building frame that emphasizes the use of round mortise and tenon joints is shown in Figures 7 and 8. Note that all of the joints are loaded in shear or bending, or in compression, but that tension load-

ing of the joints is avoided in so far as possible. Framing for doors and windows is not shown but may easily be added. Shrink and swell joint construction is not used in this building frame construction, but a close fit between tenon and mortise is desirable.

Tenons for the frame were cut with 2-inch diameter by 12-inch long deep hole saws produced by a commercial supplier. Diameter of the tenons at the time of machining was a nominal 2 inches. Mortises were drilled in the members with 2-1/16 inch diameter Forstner bits. Diameter of the holes measured a nominal 2-1/16 inches.

Overall, the frame measured 6 by 12 feet in cross section by 9 feet tall. These dimensions were chosen in order to allow the use of material that had previously been processed from small-diameter timber (Serrano 1999). All of the material was first cut to size. Tenons were then cut on the ends of the members and mortises drilled into the sides of the members as needed.

Construction of the frame itself began with the insertion of the floor joist tenons into the corresponding mortises in the sills. Once this was done, the resulting floor system consisting of floor joists and sills was secured on the foundation. The corner post tenons were then inserted into the corner sill mortises. Since the side sills were constructed of two pieces, wall stud tenons were inserted into the two overlapping sill joints to join these two members together. The floor joist tenons on either side of this joint were then pinned to the sills. The remaining wall studs and doorposts were then added by inserting their tenons into corresponding mortises in the sills.

The tenons of the window headers and sills were then inserted into their corresponding mortises cut in the wall studs. Next, the front and back top plates were slipped in place over the tops of the front corner and door tenons and the back wall corner and stud tenons and seated on the shoulders of the tenons. The tie beam was installed in a similar manner. The side rafter plates were then slipped

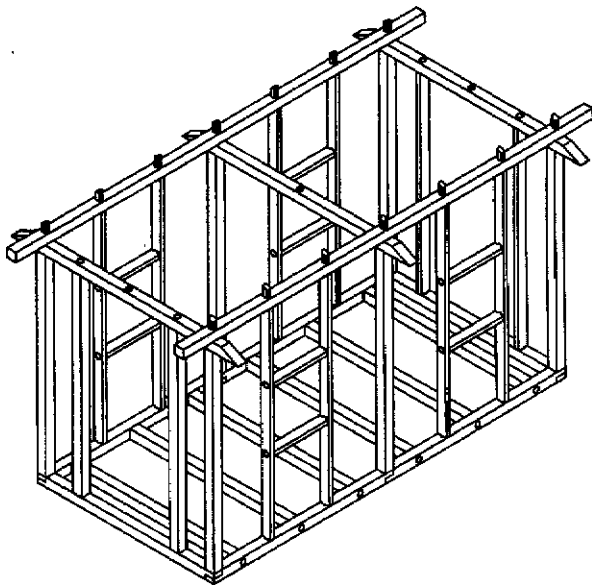

Figure 7.—Diagram showing installation of the tie beam and side rafter plates.

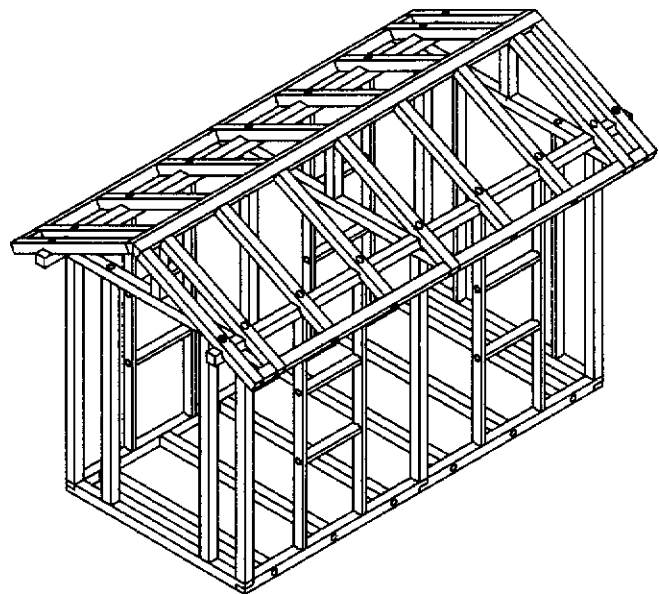

Figure 8.—Diagram showing roof frame assembly.

in place over the ends of the sidewall stud tenons and the corner post tenons (Fig. 8).

The ridge beam support columns, or king posts, were next inserted in place. Then, the rafters were slipped into place over the tops of the wall stud tenons while the rafter tenons simultaneously were slipped into corresponding mortises in the ridge beam. Each rafter was “pinned” to its corresponding wall stud tenon with a 12-penny nail. It should be noted that the outer faces of the ridge beam were cut at an angle so that they were perpendicular to the longitudinal axes of the rafters. The ridge rafter beam along with the side rafter plates were extended beyond the front and back plates in order to support fly rafters needed to provide an overhang for the front and back of the structure (Fig. 8). Finally, the fascia headers were added.

After the frame was erected, the walls and roof were sheathed with appropriate standard grades of plywood and the roof covered with asphalt shingles. Treated fascia boards were used to cover the exposed face of the fascia headers. Short lengths of fascia were also installed in each gable end. Finally, the building was floored with additional material salvaged from small-diameter yellow-poplar stems.

Construction of the frame is such that the sills are locked together at the corners by the corner post tenons. These joints locate the corners of the structure and provide resistance to lateral loading of the sills. Likewise, the sills are linked together at the mid-length points by the tenons of the wall studs supporting the tie beam. If the sills are not fastened to a secure foundation, the floor joist tenons, which frame into the sills on either side of the intermediate sill joint, are pinned to the sills in order to provide resistance to lateral loading.

The front and back top plates along with the tie beam provide resistance to lateral forces applied to the walls by the side rafter plates and also locate the position of the tops of the corner posts spatially in a side-to-side direction.

Vertical forces applied to the ridge rafter beam by the rafters are transferred to the front and back top plates and the tie beam by the ridge beam support posts, or, king posts. Hence, the ridge beam roof loads are transferred to the top plates at their center points. For longer spans, intermediate beam and column construction can be used so that these loads would be transmitted to the third or quarter points of the end plates and tie beams as desired. The rafters are notched and mortised so that they slip over the tenons of the wall studs and seat on the top surface of the side rafter plates. The side rafter plates therefore, carry a large part of the vertical roof load and also provide resistance to the horizontal components of the roof load.

The frame was first erected within the Wood Research Laboratory, disassembled, transferred to the construction site, and then re-erected (Figs. 9 and 10). Time to disassemble was about 15 minutes; time to re-assemble was about 40 minutes. The consensus of those participating was that structures such as this could be assembled easily and rapidly from a stock of standardized parts—essentially without the use of any tools.

It was found that when parts with matching tenons and mortises were allowed to dry, the mortises often shrank more than the tenons. The closeness of fit between tenons

and mortises is quite important since the tighter the joint the stiffer the structure. On the other hand, the tighter the fit, the more difficult the assembly of the frame. Unequal shrinkage could be a serious problem with parts pre-cut from green or partially seasoned wood that are stored for significant periods of time before assembly. Ideally, such parts should be cut from seasoned wood.

## DISCUSSION AND CONCLUSIONS

Although round mortise and tenon construction has been used in furniture for hundreds of years, its value in the solution of human needs problems has never been fully appreciated. Round mortise and tenon joints together with shrink and swell construction allow low cost, durable furniture to be constructed from essentially waste woody materials using only the simplest manufacturing techniques. Thus, attractive affordable school and domestic furniture of all kinds, built to “last a lifetime—and more,” can be constructed in even the most remote regions of the world from locally available materials using only low technology processes. Only a small investment is required to empower local communities to develop their own production facilities. At the same time, the same processes are readily adaptable to the production of durable maintenance free furniture in even the most developed countries.



Figure 9.—In progress assembly of the frame.



Figure 10.—The nearly completed frame.

The use of round mortise and tenon joinery in conventional building frame construction provides a means of utilizing extensive wood plantation thinnings in the solution of housing shortages as well as a means of producing low cost farm and light industrial buildings. Significant research remains to be carried out to determine the strength of the joints, optimum frame constructions, and the types of preservative treatments needed to ensure the durability of the constructions. Likewise, research is also needed to determine those wood species best suited for use in this type of construction. To date, research on building frame constructions has been carried out with what are essentially large models. As soon as concurrent joint strength and durability tests are completed, full scale building construction and testing will be undertaken. Once the necessary research is completed, however, it is anticipated that standardized modular designs can be created that require a minimum number of part sizes and limited quality control practices in order to produce simple, easy to build, robust, durable frame constructions—with basically unskilled labor.

In conclusion, therefore, it appears that round mortise and tenon joints along with the fortuitous development of the hole saws needed to make them provides a rare opportunity for improving the quality of life of many peoples of the earth while simultaneously using what would otherwise be considered wood waste. It is a particularly unique opportunity in that it provides environmentally friendly solutions to chronic social problems. Results of this program will not be translated into practice, however, unless political support is developed for the program, ways are found to transmit the information to those who most need it, and local production facilities are developed to implement the findings.

This program began with a problem and developed a solution. It is still open to whatever local factors may be relevant. The simplicity and fundamental nature of the proposed solutions lead naturally to local and regional experimentation that is expected to develop naturally and to future collaboration among public agencies, training institutions, and governmental bodies. In short, it leads to local empowerment through the broad-based participation of local populations and relevant regional agencies.

## REFERENCES

- Serrano, R. 1999. Longitudinal Growth Strain Effect on Lumber Warp from Small Yellow-Poplar Logs. Ph.D. Thesis. 296 pp. Purdue University, West Lafayette, Indiana.
- Sloane, E. 1967. *An Age of Barns*. Ballantine Books. New York.
- Stern, E.G. 2001. Construction with Small-Diameter Roundwood. *Forest Products Journal* 51(4):71-82.

## Authors

Carl Eckelman  
Department of Forestry and Natural Resources  
Purdue University  
1200 Forest Products Building  
West Lafayette, IN 47907-1200

Eva Haviarova  
Department of Forestry and Natural Resources  
Purdue University  
1200 Forest Products Building  
West Lafayette, IN 47907-1200  
765-494-3619  
ehaviar@fnr.purdue.edu